

FFT *hemtec*

Verso – Door Aperture Hemming System

one step ahead in **INTELLIGENT** production systems



FFT*hemtec* **Verso**

Counter Roller Hemming Head | Automatic Door Aperture Hemming System

1

FFT*hemtec* **Verso**

Counter Roller Hemming Head

2

Measuring System + Components

Measuring System to detect the BIW position and components

3

Additional Components

System Specific Add Ons

1

FFT*hemtec* Verso

Counter Roller Hemming Head

one step ahead in **INTELLIGENT** production systems

FFT*hemtec* Verso

Counter Roller Hemming Head

Application

- Door Aperture
- Wheel Arch
- Sidewall

Hemming Geometries

- Flat Hem
- Rope Hem

Features

- Counter Roller Hemming System
- for pre- and final hemming
- hemming pressure can be adjusted in the process by a proportional valve
- floating in vehicle Y direction to avoid deformations

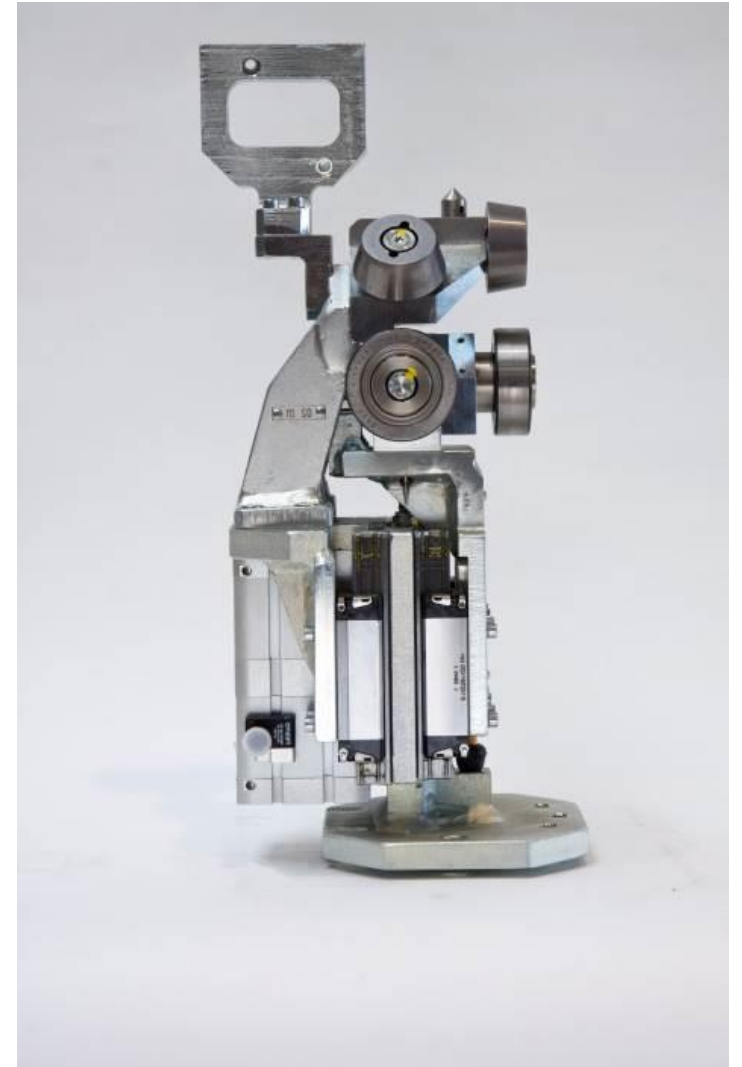

FFT*hemtec* Verso

Hemming in Door Aperture and Sidewall Area

The Counter Roller System of **FFT*hemtec* Verso** enables it to do hemming tasks without a hemming bed.

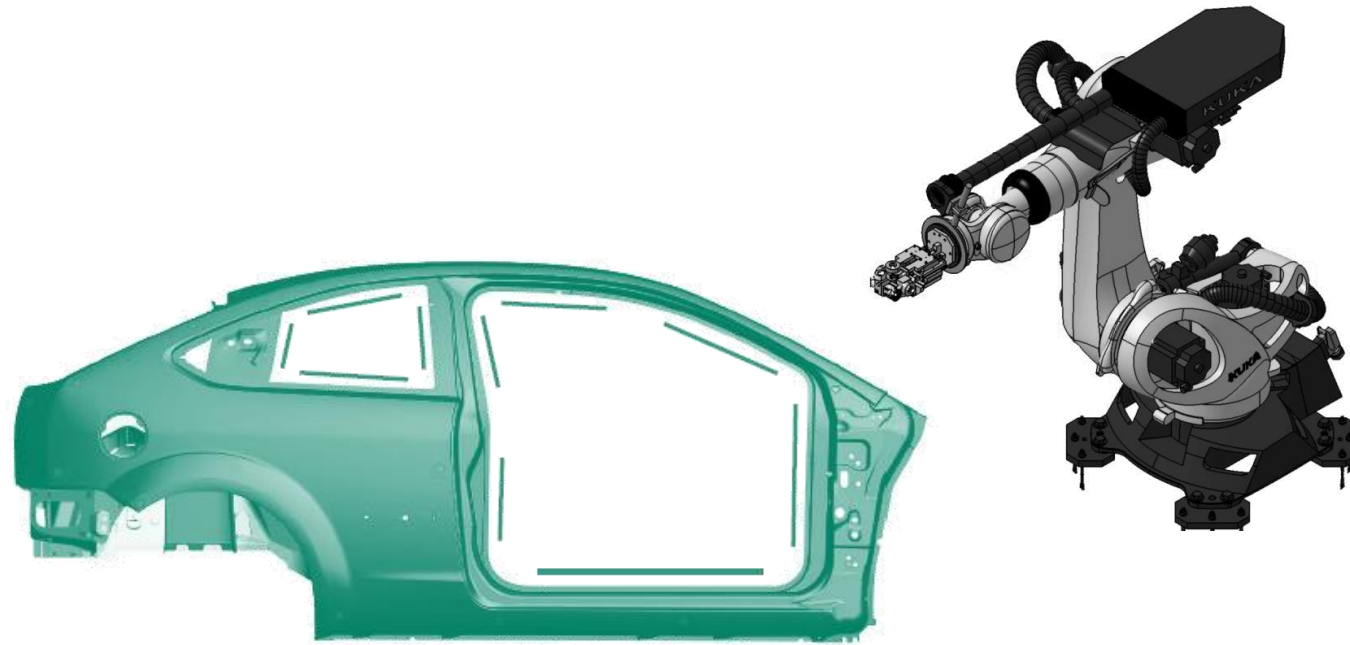

2

Measuring System + Components

Measuring System to detect the BIW position and components

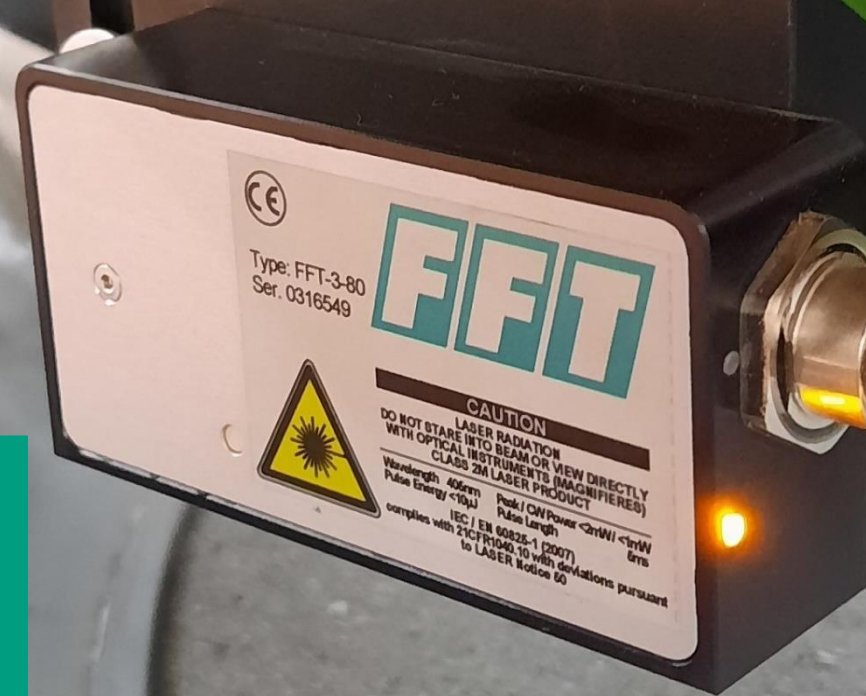

one step ahead in **INTELLIGENT** production systems

Measuring System + Components

Components and Cable Overview

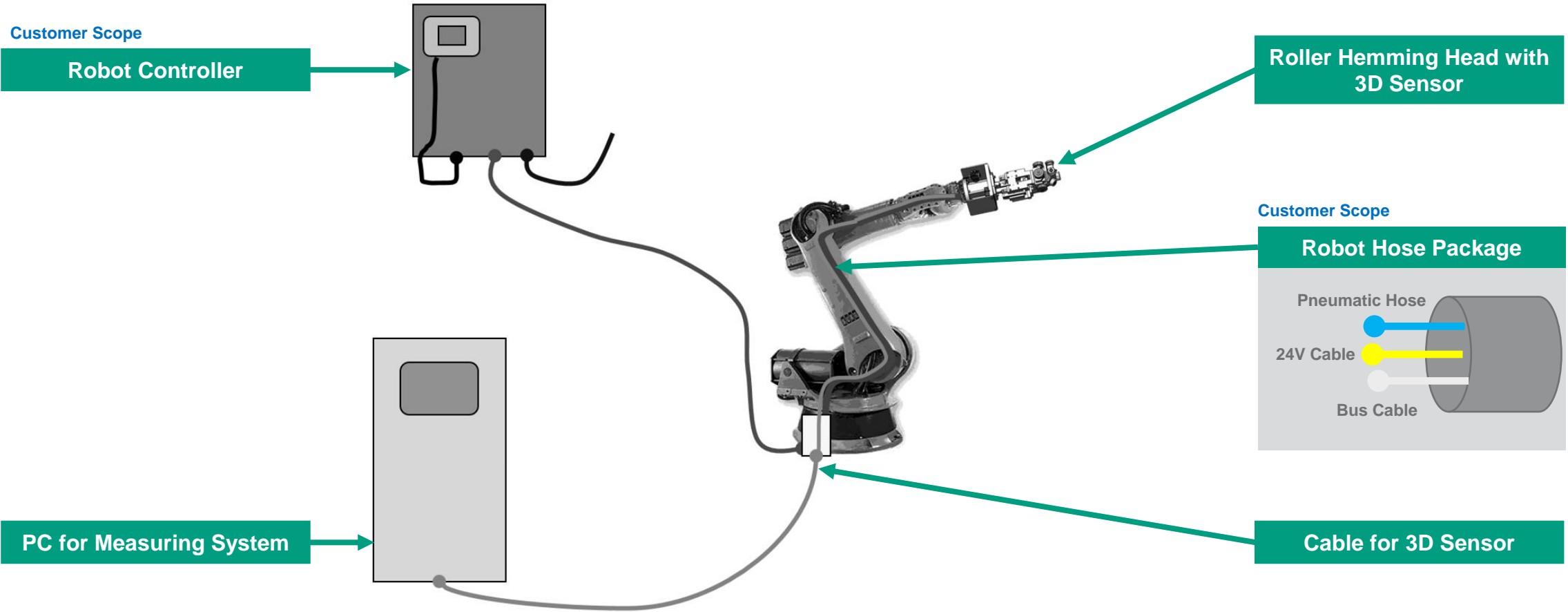

3

ADDITIONAL COMPONENTS

system specific add-ons

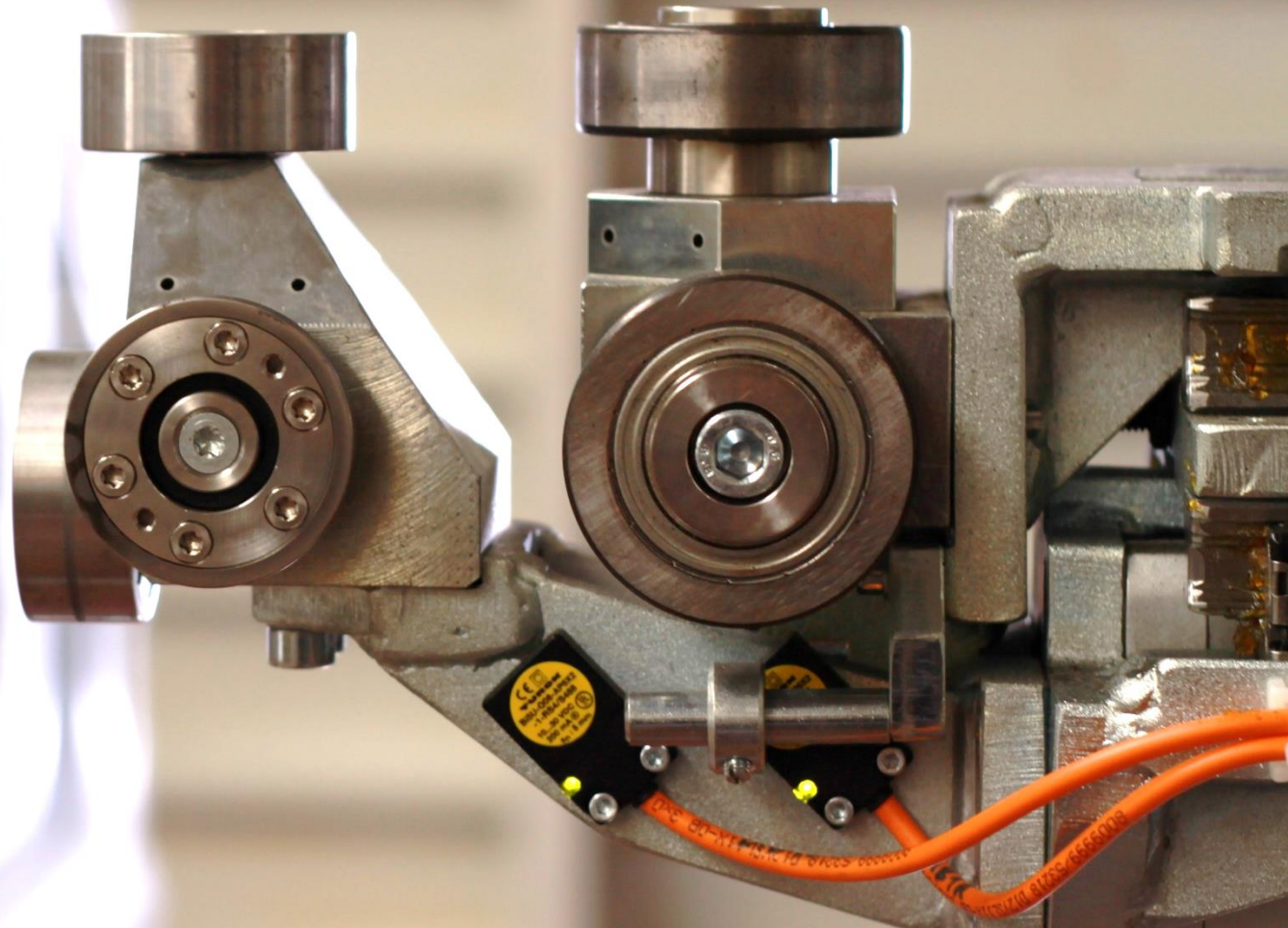

one step ahead in **INTELLIGENT** production systems

ADDITIONNAL COMPONENTS

FFT HA 130 RC – Roller Cleaning Device

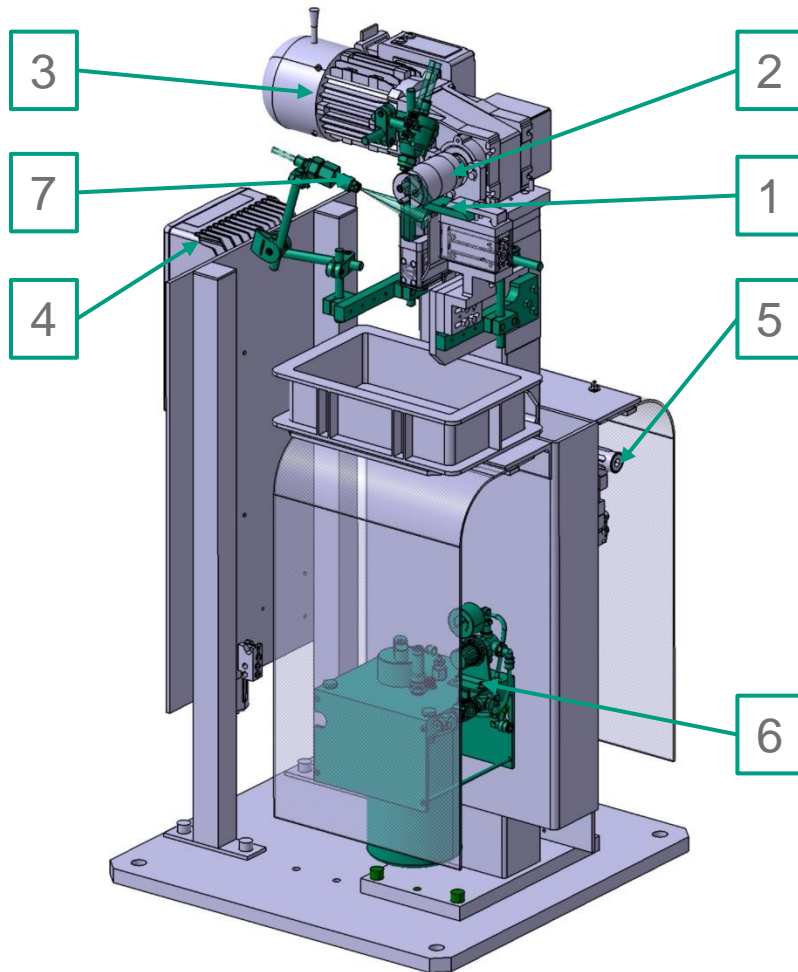

The FFT Roller Cleaning Device automatically cleans the hemming rollers without interrupting the automatic cell operation.

1. Roller Specific Scrapers
2. Drive Element for Hemming Roller
3. Electric Motor
4. Electric Cabinet
5. Valve Cluster
6. Oil Tank
7. Precision Oil Spray Nozzles

SERVICE OPTIONS

We support your project from the idea to the realization and gladly beyond.



We take into account quality and deadline requirements and we assume the responsibility for the project until turnkey handover.



Consulting

Use our experience for your tasks



Project Management

Support from the idea to the start of production



Risk Analysis

Identification of risks in the process



Custom design

Creation of individual solutions



Manufacturing

Successful manufacturing with modern technologies



Documentation

Clear and logical



Conformity

Compliance with standards and regulations



After Sales

Competent service through FFT



CONTACT

Your personal contact person

Karsten Heil
Department Manager Hemming Technology

FFT Produktionssysteme GmbH & Co. KG
Schleyerstraße 1, DE-36041 Fulda
Tel.: +49 (0) 661 2926 - 593
Mobil: +49 (0) 151 – 52847845
E-Mail: Karsten.Heil@fft.de
www.fft.de



THANK YOU

Feel free to contact us.

WWW.FFT.DE | INFO@FFT.DE
TEL.: +49 (0) 661 2926-0

