

FET *hemtec*
VersoMP

one step ahead in **INTELLIGENT** production systems



FFT*hemtec* VersoMP
Semi Automatic System,
Pneumatically Driven

1

FFT*hemtec* VersoMP

System and Components

2

FUNCTIONAL DESCRIPTION

Hemming Process Description

3

VERSIONS

System Versions

1

FFThemtec VersoMP

System and Components

one step ahead in INTELLIGENT production systems

FFT*hemtec* VersoMP

System Overview

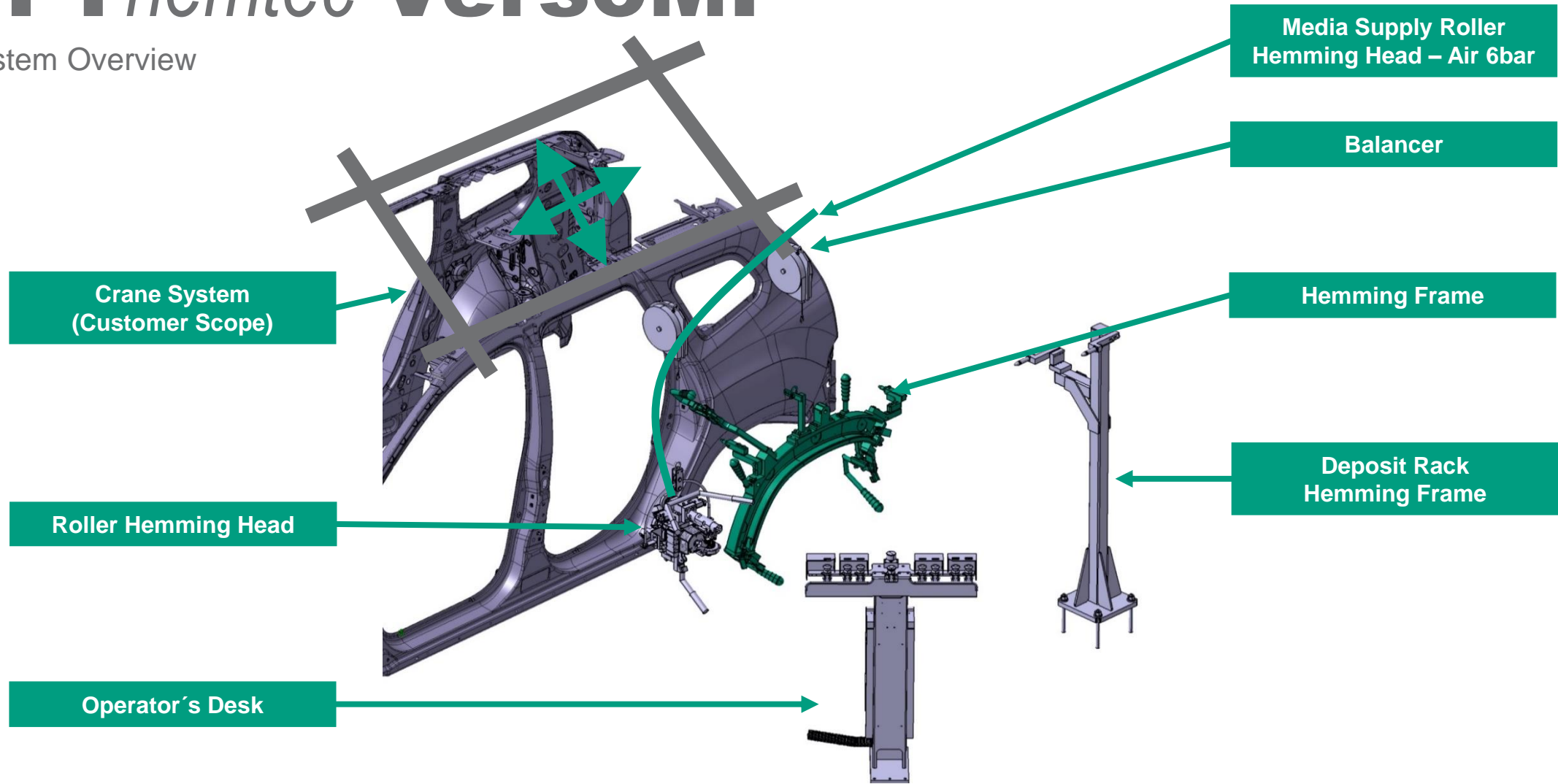

FFT*hemtec* VersoMP

Components

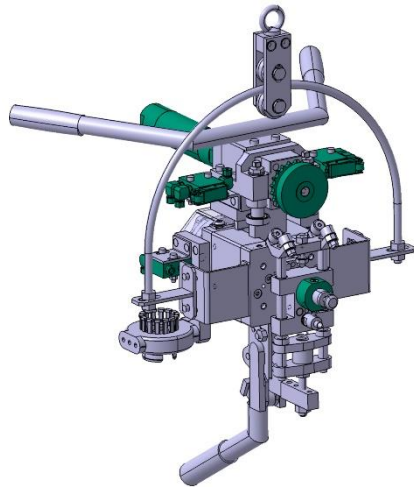

Roller Hemming Head

3 to 4 hemming steps
available for flat and rope hem

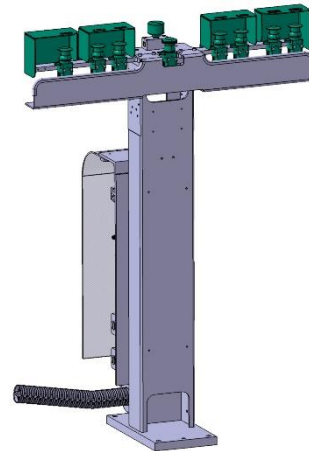

Operator's Desk

Two Hand Start for Safety

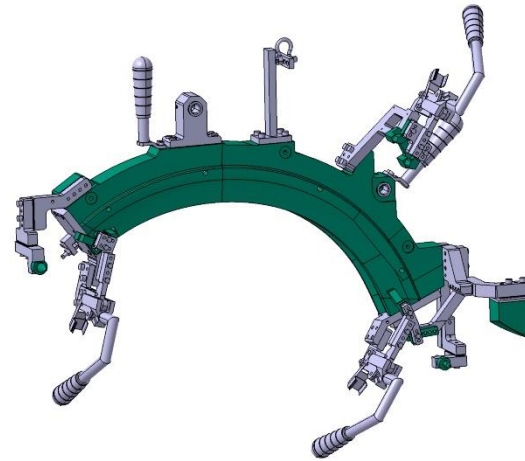

Hemming Frame

machined to the vehicle geometry

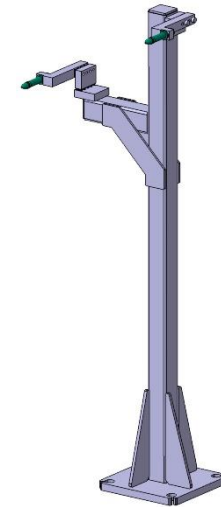

Deposit Rack

for storing the hemming frame when not in use

FFT*hemtec* VersoMP

Roller Hemming Head

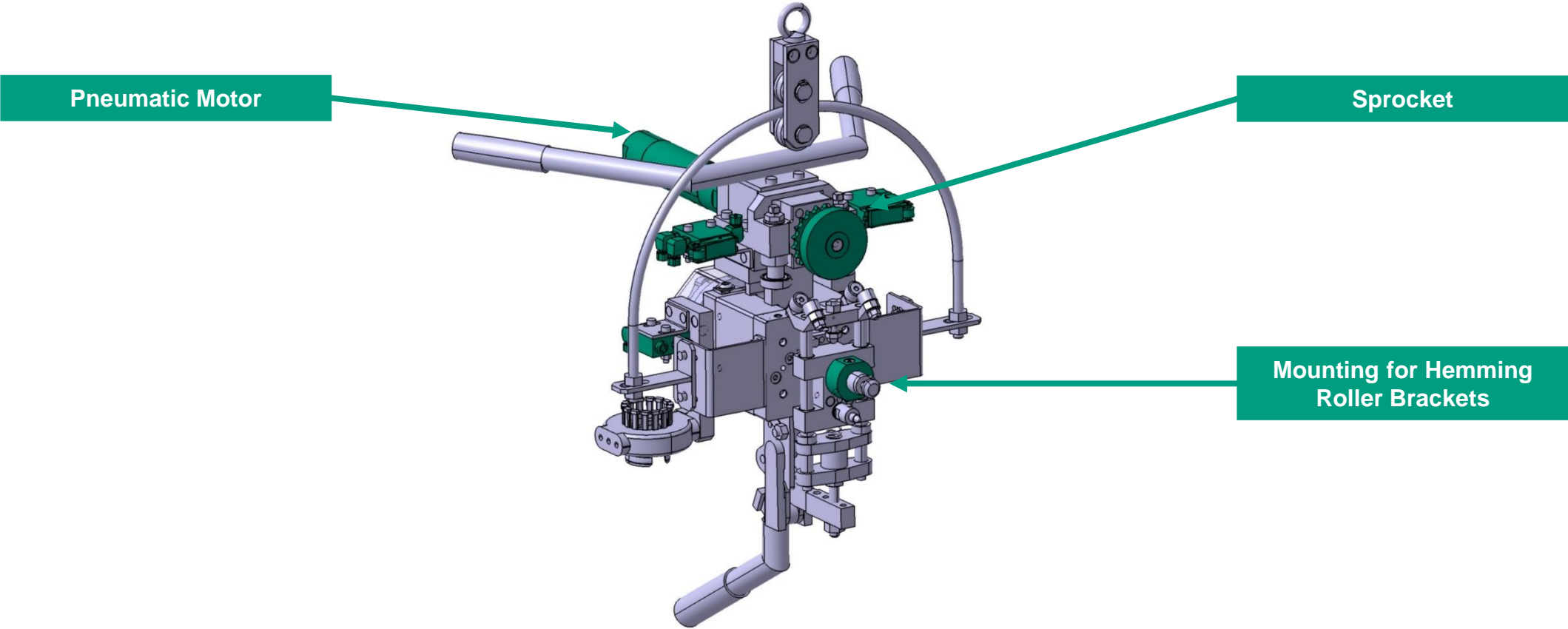

FFT*hemtec* VersoMP

Roller Hemming Head

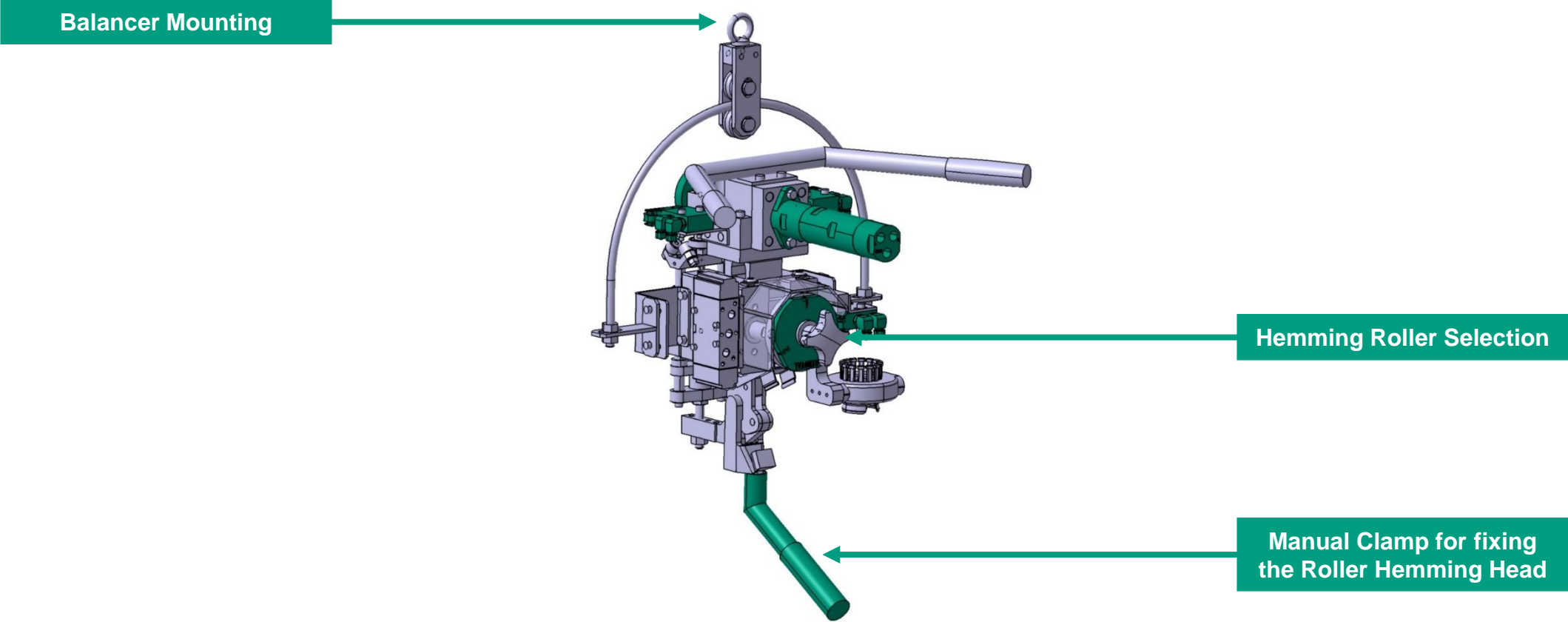

FFT*hemtec* VersoMP

Roller Bracket Flat Hem

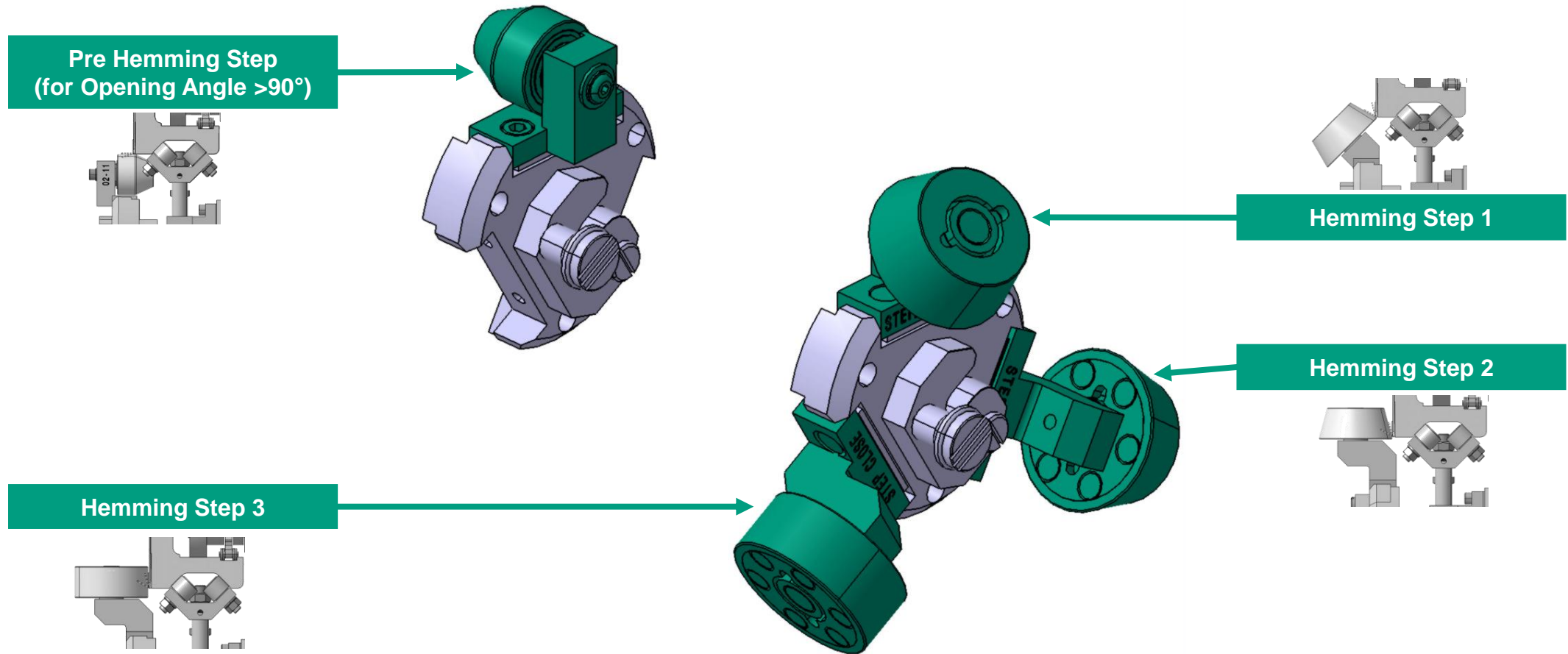

FFT*hemtec* VersoMP

Roller Bracket Rope Hem

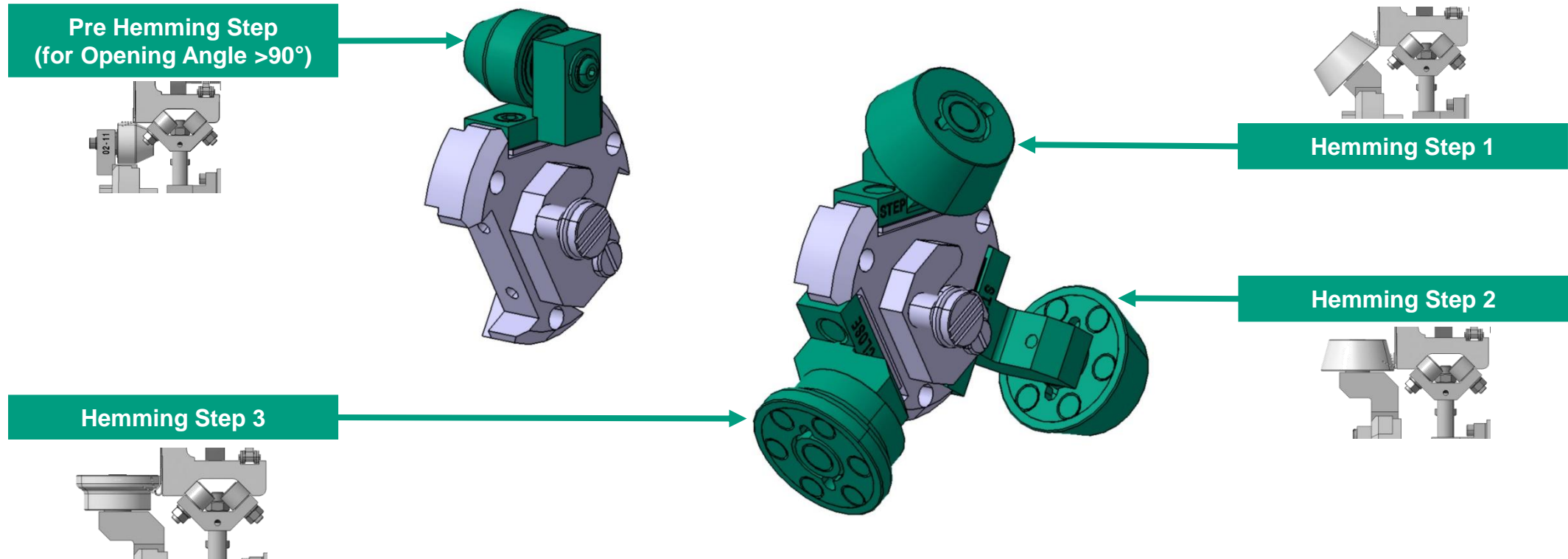

FFT*hemtec* VersoMP

Operator's Desk

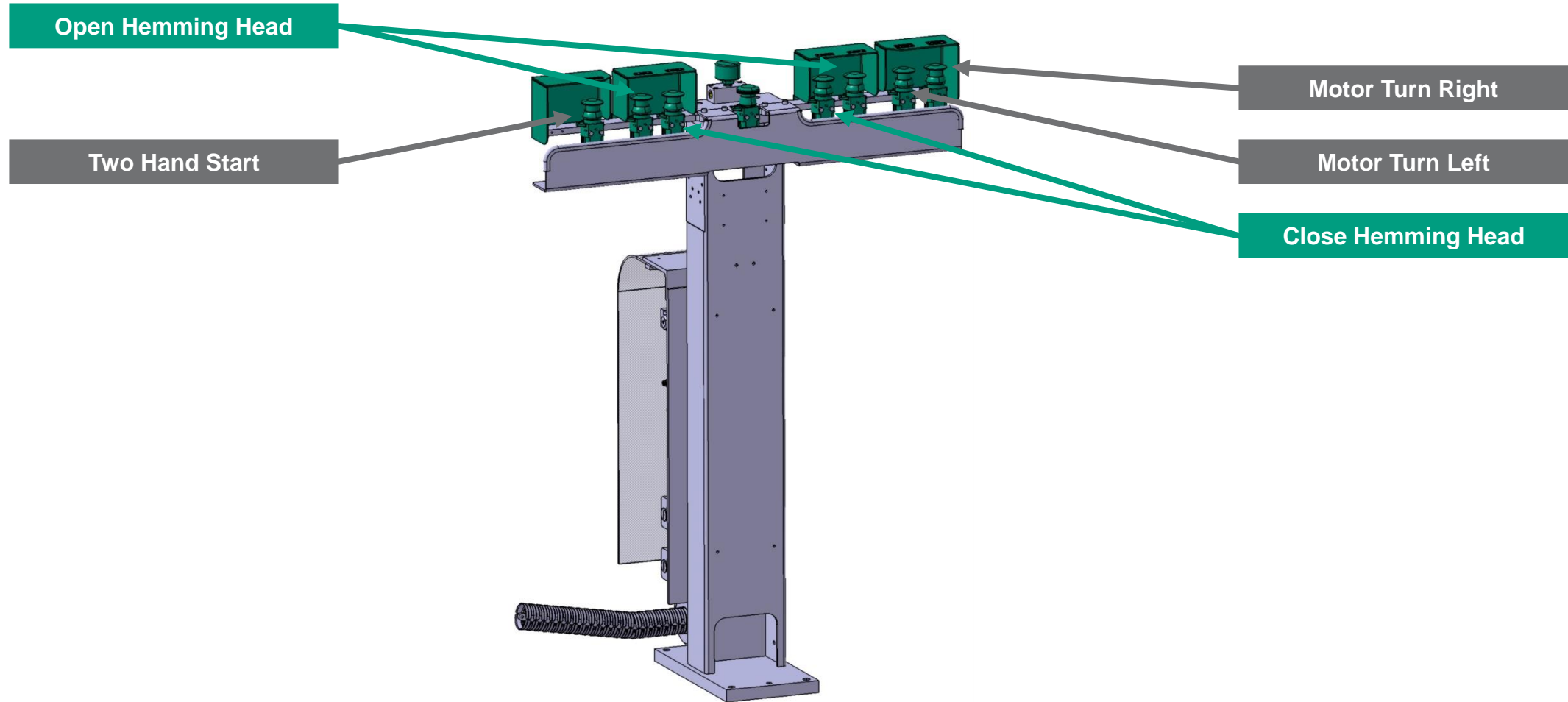

FFT*hemtec* VersoMP

Hemming Frame

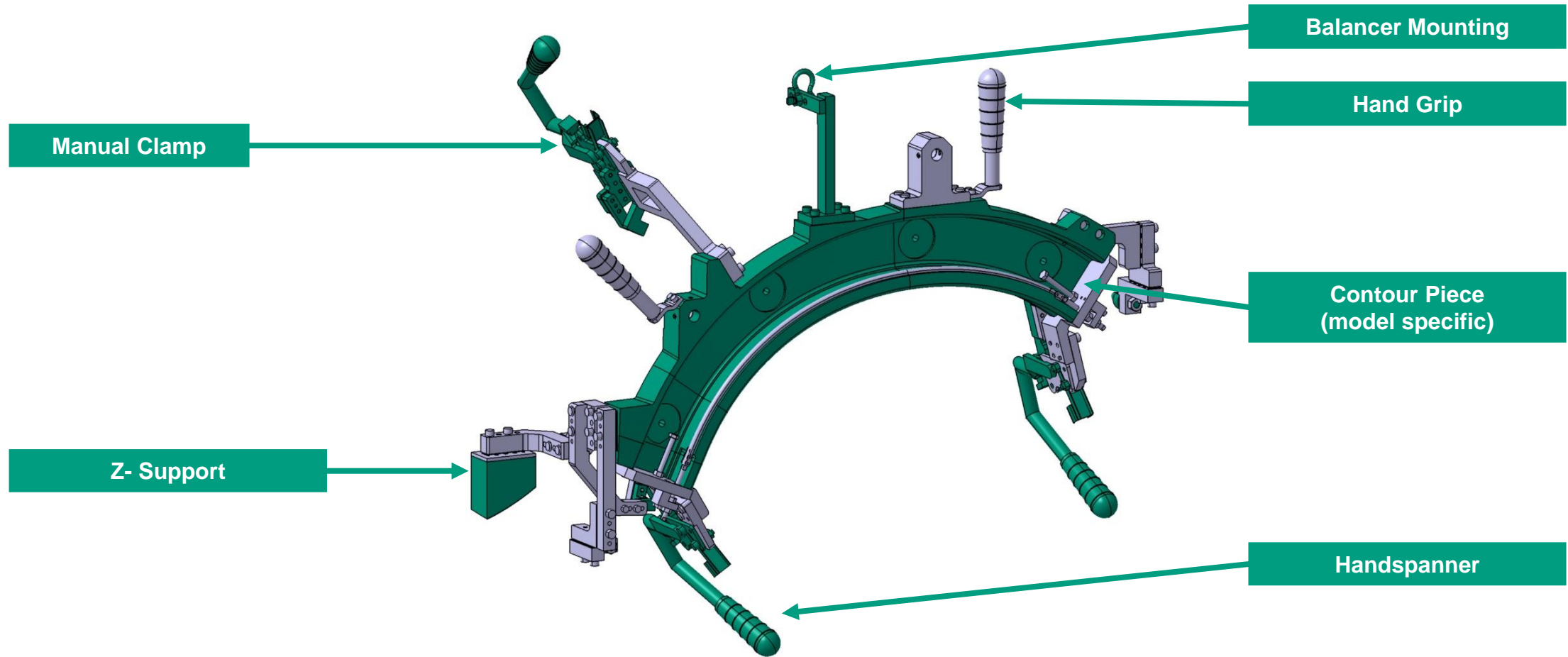

FFT*hemtec* VersoMP

Deposit Rack

Attachment Pins for Hemming Frame

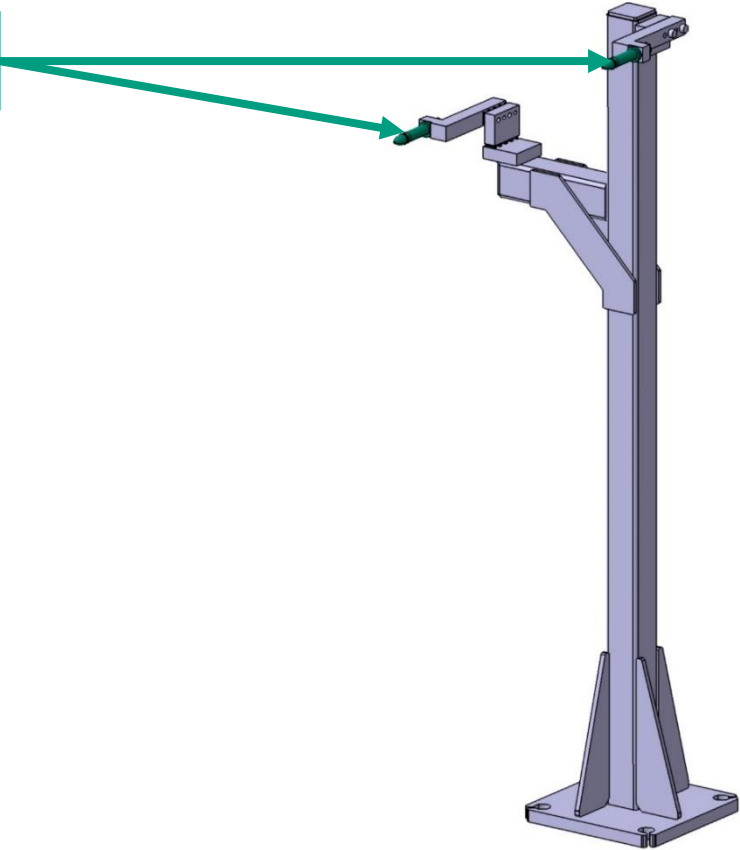

2

FUNCTIONAL DESCRIPTION

Hemming Process Description

A detailed close-up photograph of industrial machinery, likely a hemming station. The image shows various metal components, including a large cylindrical die with a central hole and a smaller die below it. The machinery is made of polished metal, possibly aluminum or steel, and is secured with numerous screws and bolts. The background is slightly blurred, focusing attention on the mechanical parts.

one step ahead in **INTELLIGENT** production systems

FUNCTIONAL DESCRIPTION

Hemming Process Description

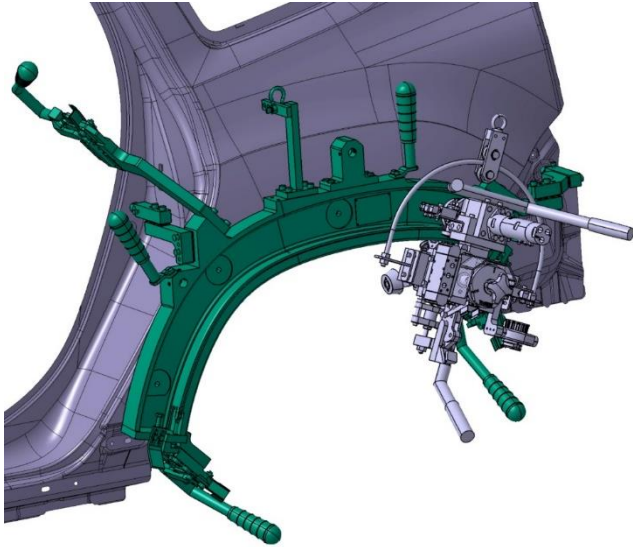

- The hemming frame is fixed manually to the car body.
- The roller hemming head is fixed on the hemming frame in the start position.

FUNCTIONAL DESCRIPTION

Hemming Process Description

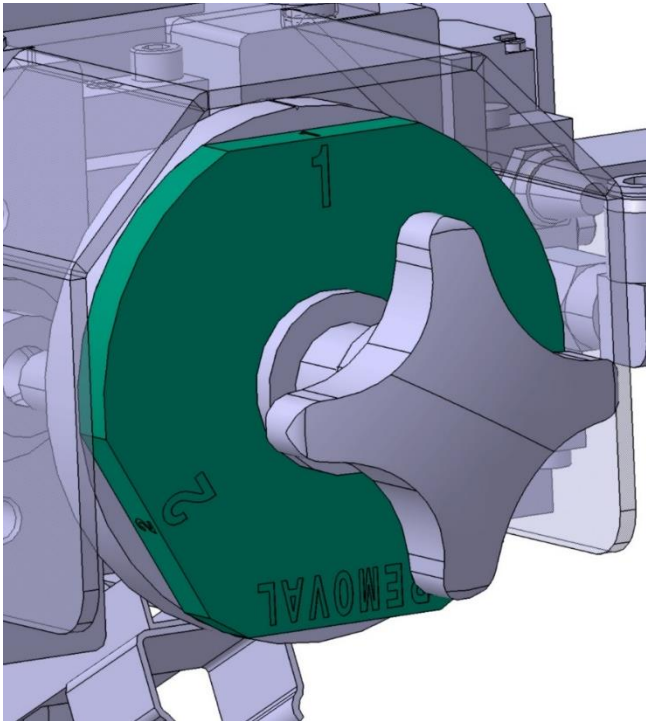

- The hemming roller 1 is moved into position manually via the selection wheel on the hemming head.
- When the two-hand start is actuated, the hemming roller is moved to the hemming frame pneumatically.

FUNCTIONAL DESCRIPTION

Hemming Process Description

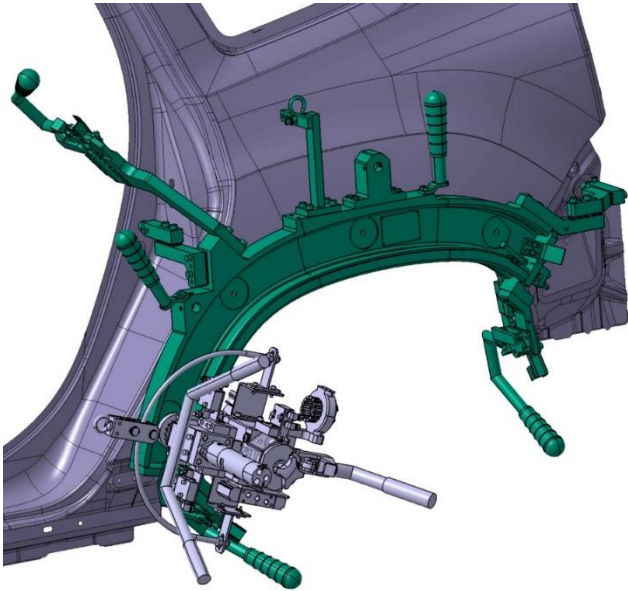

- The first hemming step is initiated by safety start on the operator's desk. The pneumatic motor stops automatically at the end position.
- At the end, the roller hemming head is opened by two-hand start and the next hemming roller is brought into position via the selection wheel.
- The process is repeated for the following hemming steps.

3

VERSIONS

System Version

one step ahead in **INTELLIGENT** production systems

VERSIONS

Pneumatic Hemming Frame

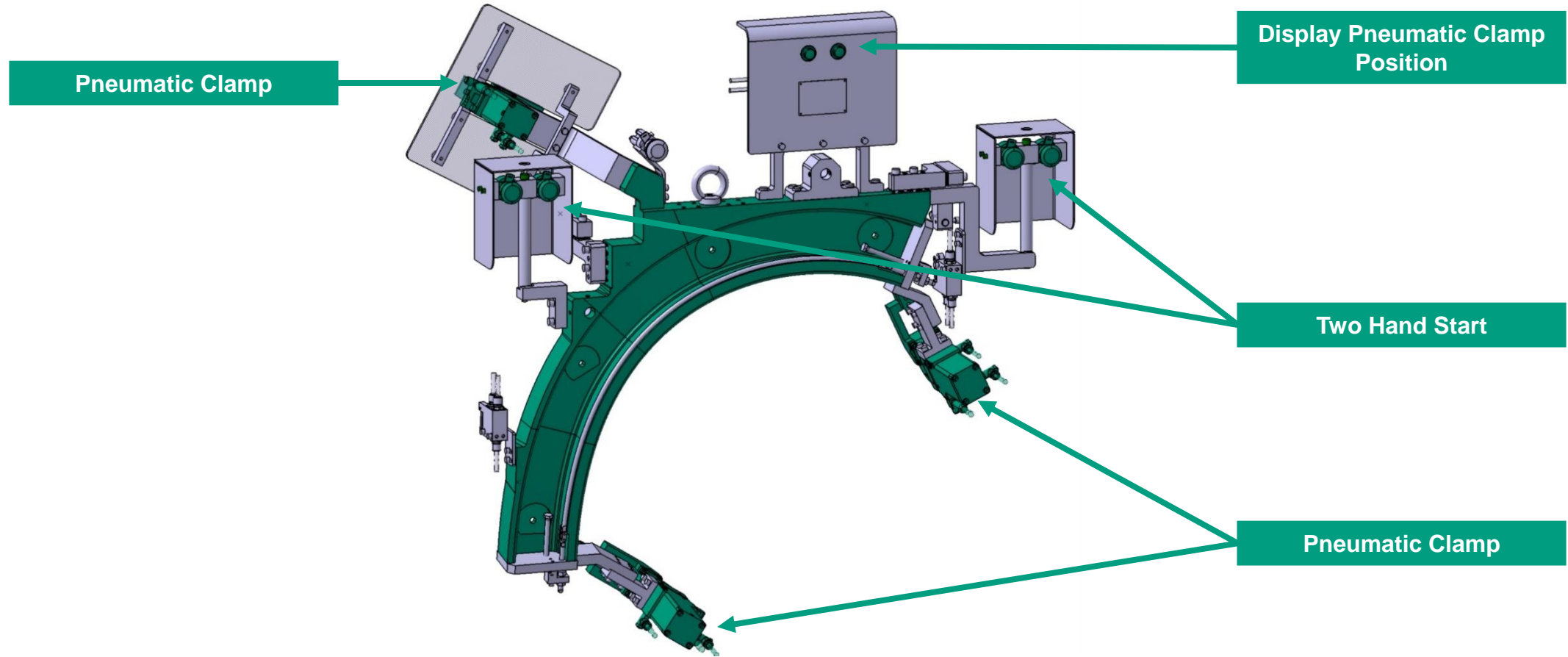

SERVICE OPTIONS

We support your project from the idea to the realization and gladly beyond.



We take into account quality and deadline requirements and we assume the responsibility for the project until turnkey handover.



Consulting

Use our experience for your tasks



Project Management

Support from the idea to the start of production



Risk Analysis

Identification of risks in the process



Custom design

Creation of individual solutions



Manufacturing

Successful manufacturing with modern technologies



Documentation

Clear and logical



Conformity

Compliance with standards and regulations



After Sales

Competent service through FFT



CONTACT

Your personal contact person

Karsten Heil
Department Manager Hemming Technology

FFT Produktionssysteme GmbH & Co. KG
Schleyerstraße 1, DE-36041 Fulda
Tel.: +49 (0) 661 2926 - 593
Mobil: +49 (0) 151 – 52847845
E-Mail: Karsten.Heil@fft.de
www.fft.de



THANK YOU

Feel free to contact us.

WWW.FFT.DE | INFO@FFT.DE
TEL.: +49 (0) 661 2926-0

