

FFTmove **Conveyor**

*"The **FFT**move **Conveyor** is used to feed parts into processing lines and loosely link different areas of the plant."*

one step ahead in **INTELLIGENT** production systems



FFT*move* Conveyor

Feeding or transferring components across cells

1

Description

Functionality of the **FFT**move **Conveyor**

2

Designs

We have a solution for every need

3

Technical information

Connection data of the accumulating conveyor

4

Advantages

Advantages and benefits for our customers



1

Description

Functionality of the **FFTmove Conveyor**

one step ahead in **INTELLIGENT** production systems

Functionality

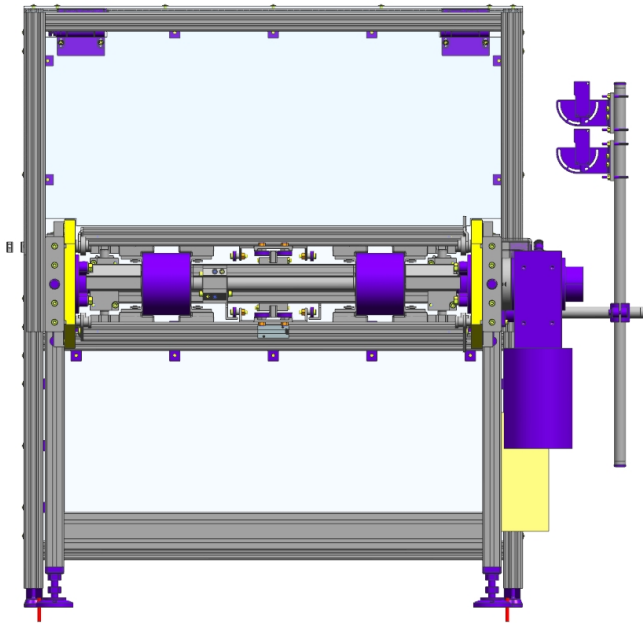

Cycle controlled component feeding



Modular design with sturdy aluminum frame



Extremely smooth running due to the use of a PU curved toothed belt (low maintenance)

Assemblies

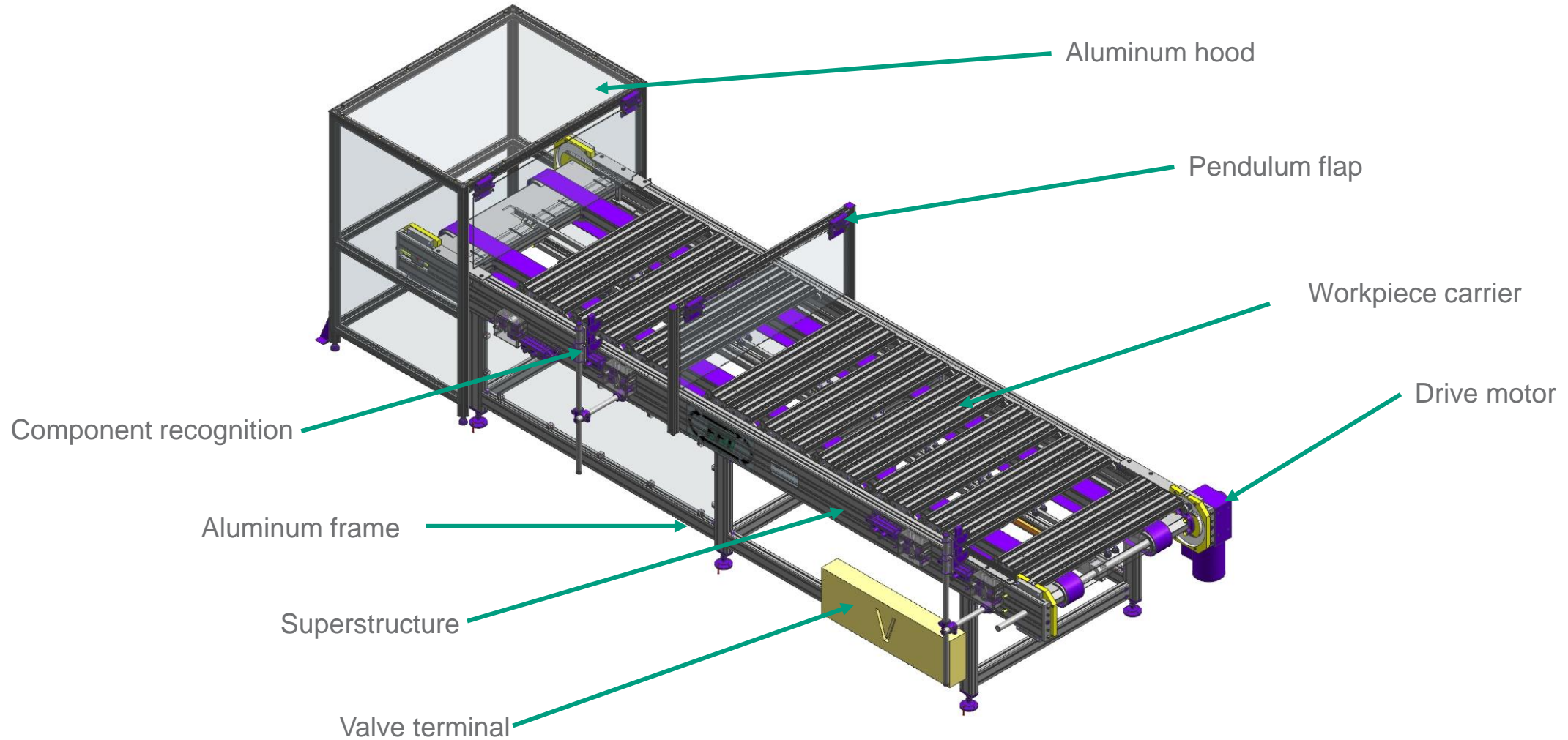

The Functionality

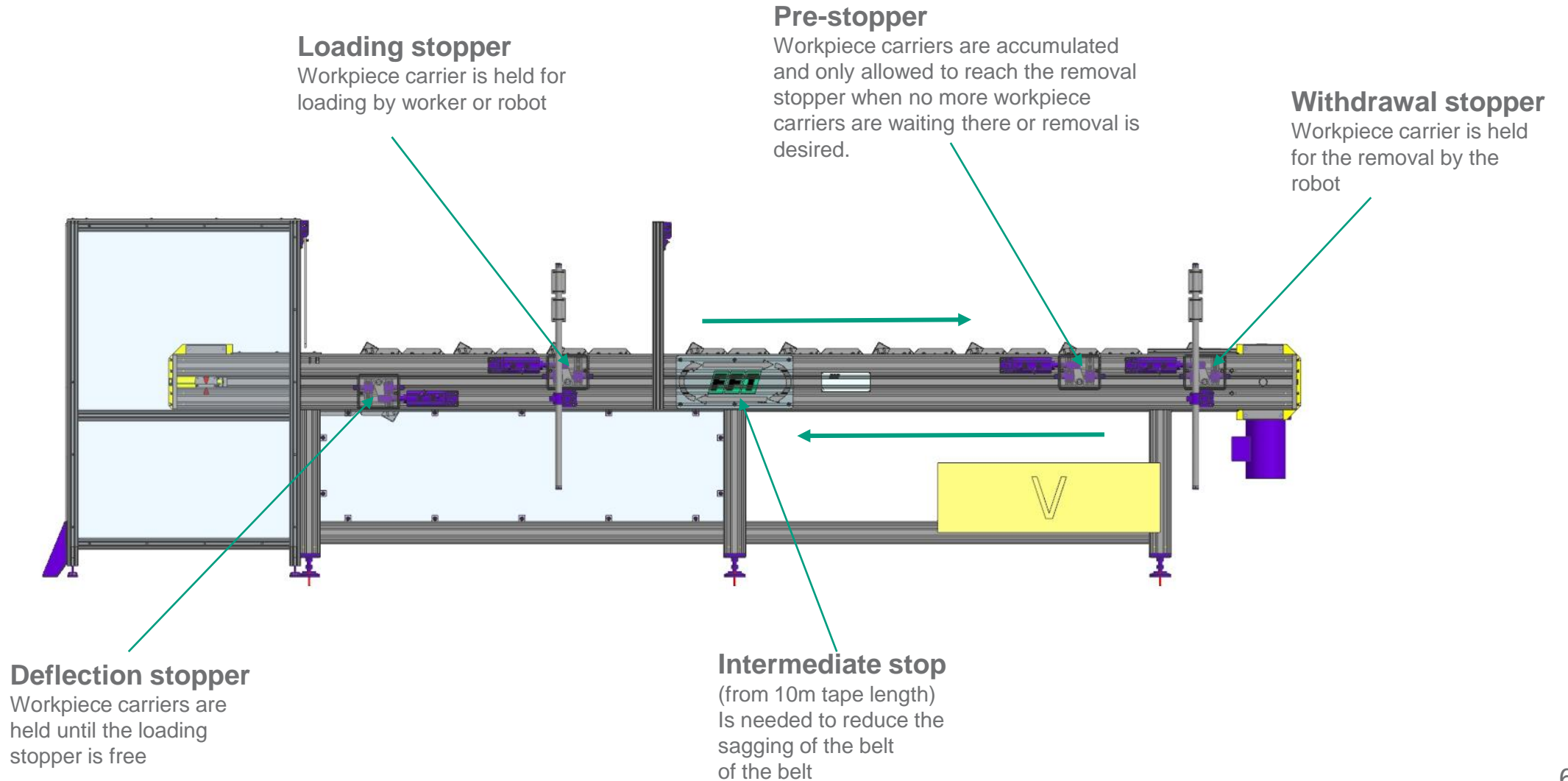

Types of Workpiece carrier

1	2	3	4	5	6	7	8																																																																																																				
A							A																																																																																																				
B	<p>In der Bestellnummer WF-10-bnr.2xx beschreiben die Stellen xx die Anzahl der WT-Profile. Daraus ergibt sich unter Berücksichtigung der Nachlaufpuffer der Pufferabstand PA. Bevorzugt sind allerdings Kombinationen ohne zusätzlichen Nachlauf zu verwenden.</p> <p>In the order number WF-10-bnr.2xx describe the places xx the number of the WT profiles. The buffer distance PA arises taking into account the caster buffers from it. However, preferentially combinations are to be used without additional caster.</p>						B																																																																																																				
C	<table border="1" style="width: 100%; border-collapse: collapse;"> <thead> <tr> <th rowspan="2">BESTELL-NUMMER</th> <th rowspan="2">ANZ. PROFILE</th> <th colspan="5">PUFFERABSTAND (PA)</th> </tr> <tr> <th>NACHLAUF 0</th> <th>16</th> <th>47</th> <th>72</th> <th>103</th> <th>128</th> </tr> </thead> <tbody> <tr> <td></td> <td></td> <td colspan="5" style="text-align: center;">VORZUGSREIHE</td> </tr> <tr> <td>WF-10-bnr.21</td> <td>1</td> <td>185</td> <td>201</td> <td>232</td> <td>251</td> <td>288</td> <td>313</td> </tr> <tr> <td>WF-10-bnr.22</td> <td>2</td> <td>335</td> <td>351</td> <td>382</td> <td>401</td> <td>438</td> <td>463</td> </tr> <tr> <td>WF-10-bnr.23</td> <td>3</td> <td>485</td> <td>501</td> <td>532</td> <td>551</td> <td>588</td> <td>613</td> </tr> <tr> <td>WF-10-bnr.24</td> <td>4</td> <td>635</td> <td>651</td> <td>682</td> <td>701</td> <td>738</td> <td>763</td> </tr> <tr> <td>WF-10-bnr.25</td> <td>5</td> <td>785</td> <td>801</td> <td>832</td> <td>851</td> <td>888</td> <td>913</td> </tr> <tr> <td>WF-10-bnr.26</td> <td>6</td> <td>935</td> <td>951</td> <td>982</td> <td>1007</td> <td>1038</td> <td>1063</td> </tr> <tr> <td>WF-10-bnr.27</td> <td>7</td> <td>1085</td> <td>1101</td> <td>1132</td> <td>1157</td> <td>1188</td> <td>1213</td> </tr> <tr> <td>WF-10-bnr.28</td> <td>8</td> <td>1235</td> <td>1251</td> <td>1282</td> <td>1307</td> <td>1338</td> <td>1363</td> </tr> <tr> <td>WF-10-bnr.29</td> <td>9</td> <td>1385</td> <td>1401</td> <td>1432</td> <td>1457</td> <td>1488</td> <td>1513</td> </tr> <tr> <td>WF-10-bnr.210</td> <td>10</td> <td>1535</td> <td>1551</td> <td>1582</td> <td>1607</td> <td>1638</td> <td>1663</td> </tr> </tbody> </table>						BESTELL-NUMMER	ANZ. PROFILE	PUFFERABSTAND (PA)					NACHLAUF 0	16	47	72	103	128			VORZUGSREIHE					WF-10-bnr.21	1	185	201	232	251	288	313	WF-10-bnr.22	2	335	351	382	401	438	463	WF-10-bnr.23	3	485	501	532	551	588	613	WF-10-bnr.24	4	635	651	682	701	738	763	WF-10-bnr.25	5	785	801	832	851	888	913	WF-10-bnr.26	6	935	951	982	1007	1038	1063	WF-10-bnr.27	7	1085	1101	1132	1157	1188	1213	WF-10-bnr.28	8	1235	1251	1282	1307	1338	1363	WF-10-bnr.29	9	1385	1401	1432	1457	1488	1513	WF-10-bnr.210	10	1535	1551	1582	1607	1638	1663	C
BESTELL-NUMMER	ANZ. PROFILE	PUFFERABSTAND (PA)																																																																																																									
		NACHLAUF 0	16	47	72	103	128																																																																																																				
		VORZUGSREIHE																																																																																																									
WF-10-bnr.21	1	185	201	232	251	288	313																																																																																																				
WF-10-bnr.22	2	335	351	382	401	438	463																																																																																																				
WF-10-bnr.23	3	485	501	532	551	588	613																																																																																																				
WF-10-bnr.24	4	635	651	682	701	738	763																																																																																																				
WF-10-bnr.25	5	785	801	832	851	888	913																																																																																																				
WF-10-bnr.26	6	935	951	982	1007	1038	1063																																																																																																				
WF-10-bnr.27	7	1085	1101	1132	1157	1188	1213																																																																																																				
WF-10-bnr.28	8	1235	1251	1282	1307	1338	1363																																																																																																				
WF-10-bnr.29	9	1385	1401	1432	1457	1488	1513																																																																																																				
WF-10-bnr.210	10	1535	1551	1582	1607	1638	1663																																																																																																				
D							D																																																																																																				
E	<p>DARSTELLUNG BEISPIEL WF-10-bnr.23 MIT NACHLAUF 128 Representation example WF-10-bnr.23 with caster 128</p>						E																																																																																																				
F	<table border="1" style="width: 100%; border-collapse: collapse;"> <tr> <td style="width: 15%;">DATUM/DATE:</td> <td style="width: 15%;">07.11.12</td> <td style="width: 15%;">BEZÜGLICH / TITLE:</td> <td colspan="2" style="text-align: center;">WERKSTÜCKTRAEGER</td> <td style="width: 15%;">MASSST./SCALE:</td> <td style="width: 15%;">SEITE/PAGE:</td> </tr> <tr> <td>BEARB./PREP.:</td> <td>LOROESCH</td> <td>ZEICHN.-NR./DRAWING NO.:</td> <td colspan="2" style="text-align: center;">WF-10-bnr.2xx</td> <td>17:00</td> <td>1 +</td> </tr> <tr> <td>GEPR./CHECK.:</td> <td>LOROESCH</td> <td>STAND/STATE:</td> <td colspan="2"></td> <td></td> <td></td> </tr> </table>						DATUM/DATE:	07.11.12	BEZÜGLICH / TITLE:	WERKSTÜCKTRAEGER		MASSST./SCALE:	SEITE/PAGE:	BEARB./PREP.:	LOROESCH	ZEICHN.-NR./DRAWING NO.:	WF-10-bnr.2xx		17:00	1 +	GEPR./CHECK.:	LOROESCH	STAND/STATE:					F																																																																															
DATUM/DATE:	07.11.12	BEZÜGLICH / TITLE:	WERKSTÜCKTRAEGER		MASSST./SCALE:	SEITE/PAGE:																																																																																																					
BEARB./PREP.:	LOROESCH	ZEICHN.-NR./DRAWING NO.:	WF-10-bnr.2xx		17:00	1 +																																																																																																					
GEPR./CHECK.:	LOROESCH	STAND/STATE:																																																																																																									
1	2	3	4	5	6	7	8																																																																																																				

2

Designs

We have a solution for every need

A detailed view of an industrial machine, likely a conveyor or sorting system, featuring a complex arrangement of aluminum extrusions, rollers, and gears. A prominent red metal bar is visible in the center. On the right side, several orange cables are bundled together and connected to a blue control unit. A white label with technical specifications is attached to the machine's frame.

one step ahead in **INTELLIGENT** production systems

Designs

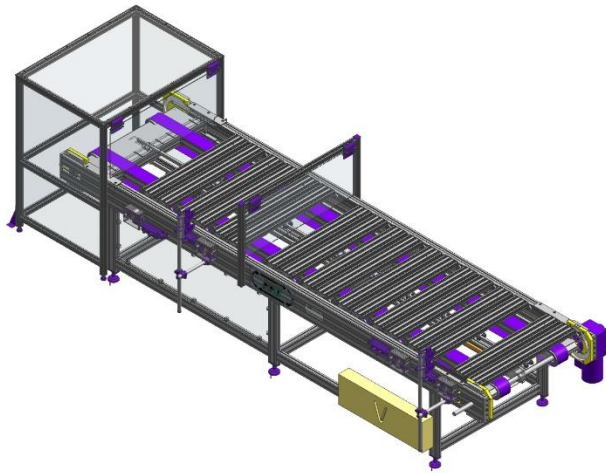

Floor standing

- With aluminum hood and pendulum flap for loading by the worker
- Also without aluminum hood and pendulum flap for a transport between the cells

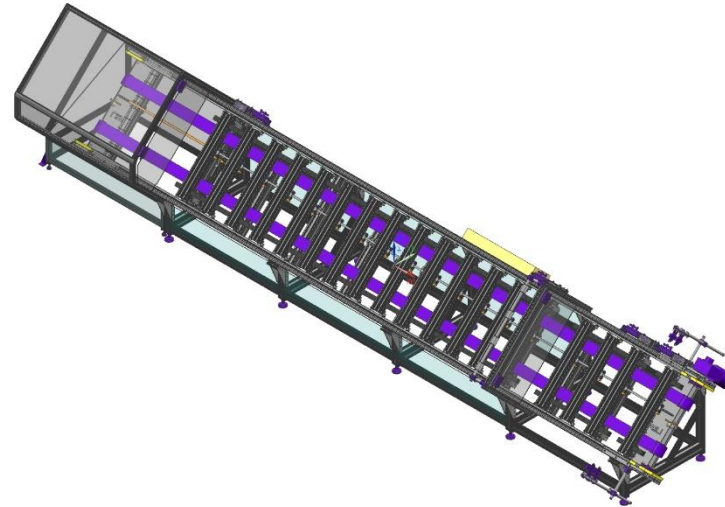

Floor standing 45° substructure

- Optimal ergonomics for loading by the worker



Steel construction

- Cross-cell transport of large components (transported overhead)

3

Technical information

Connection data of the **FFT**move **Conveyor**

one step ahead in **INTELLIGENT** production systems

R004.82
Best. Nr. 2
WF-10-1



We support our customers in efficiently implementing their production systems according to their specifications.

“

DO YOU NEED AN
INDIVIDUAL SOLUTION
FOR YOUR TASK?

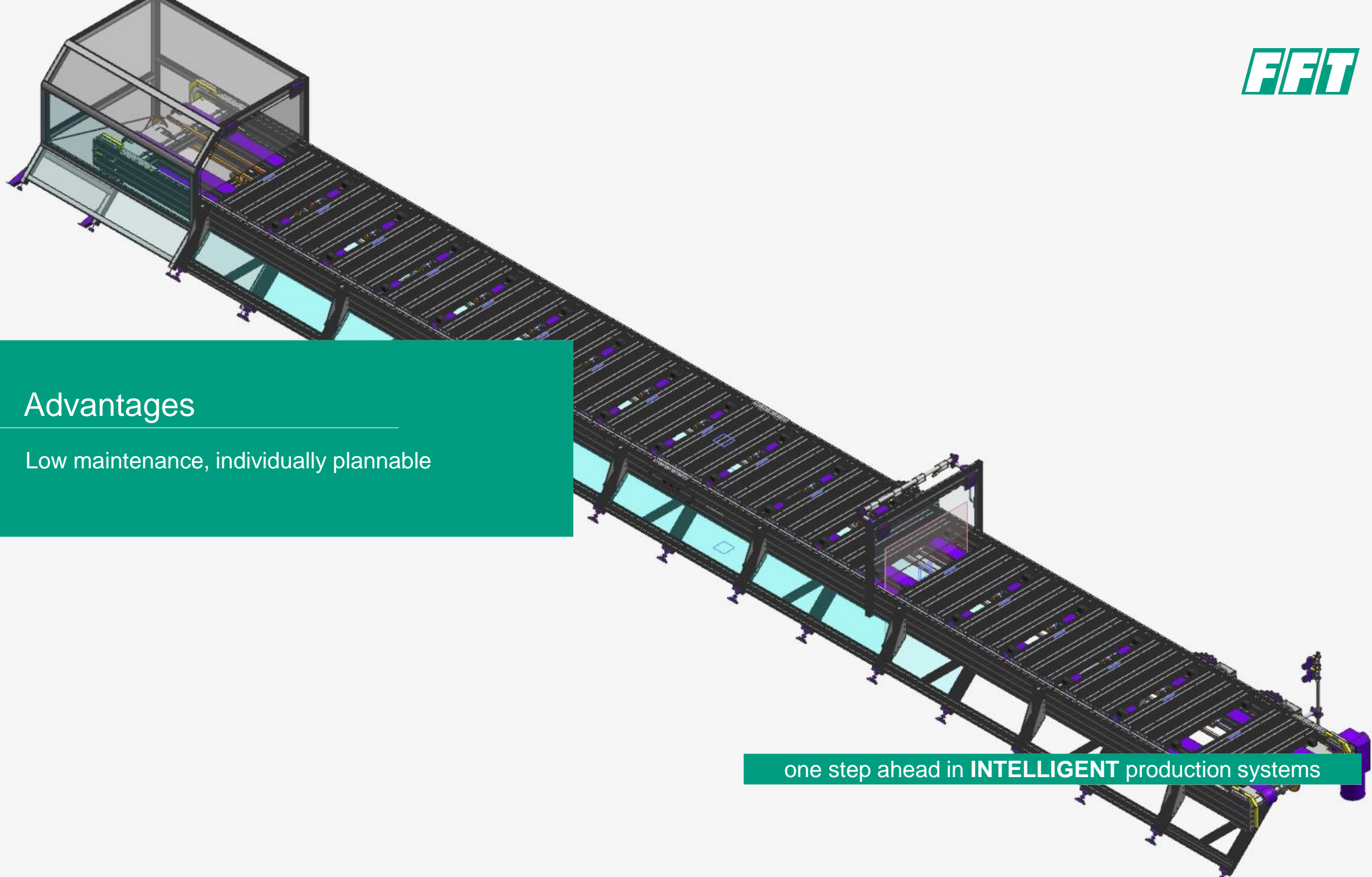

4

Advantages

Low maintenance, individually plannable

one step ahead in **INTELLIGENT** production systems

Advantages of the **FFT**move **Conveyor**

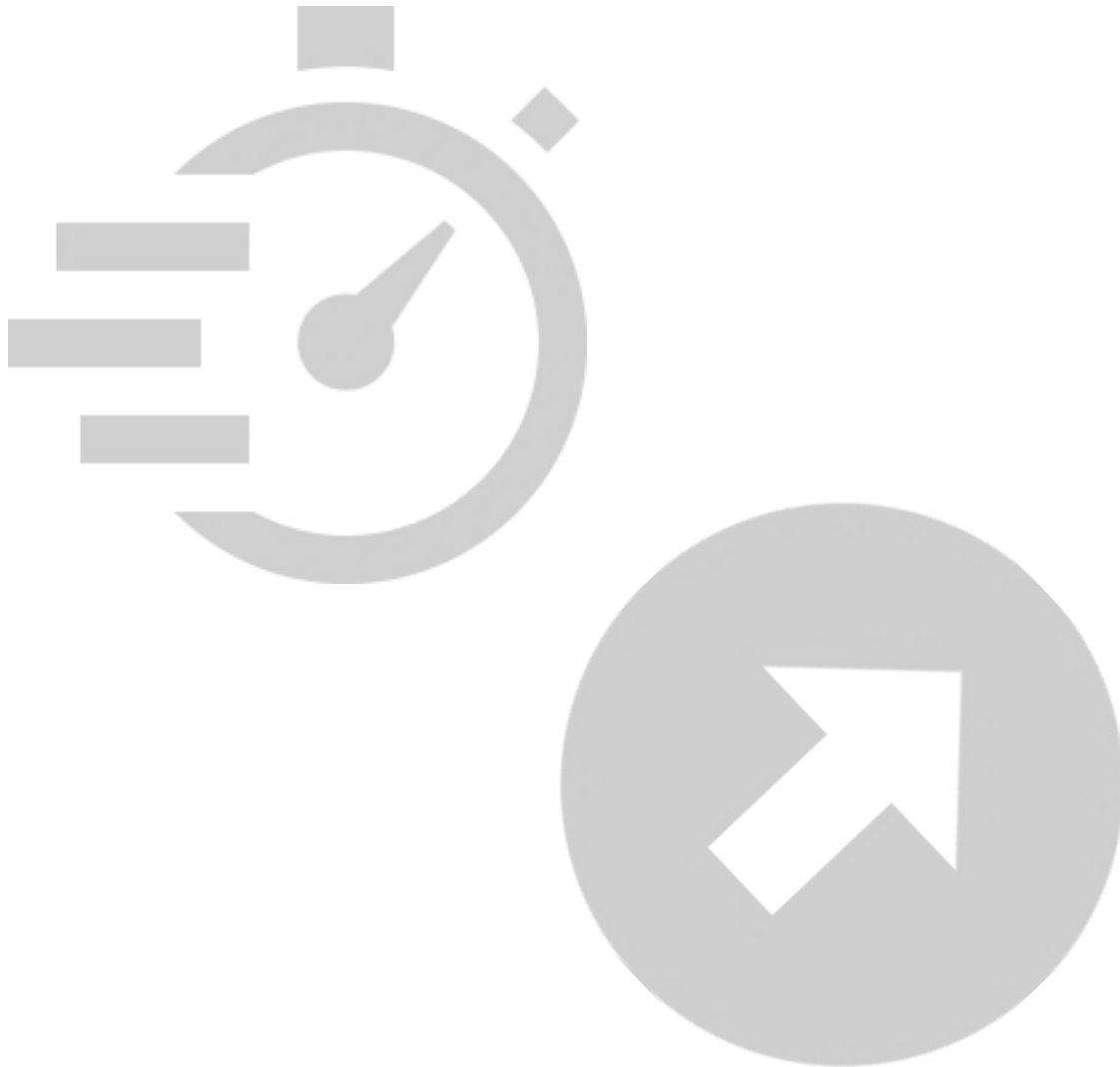

Vorteile

- Increased flexibility through coupling of several workpiece carriers
- Modular design with stable aluminum frame
- Cycle-controlled component feeding
- Various designs
- No lubrication necessary
- Storage of fed components
- Cable routing within the aluminum profile
- Extremely smooth running due to the use of a PU curved-tooth belt (low maintenance)
- No automatic belt tensioning necessary

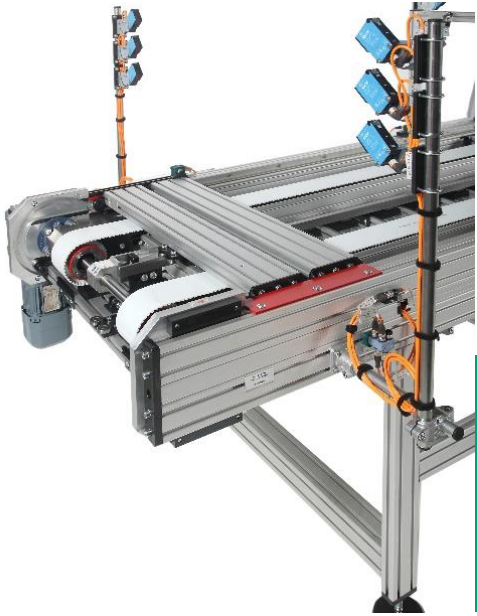

SERVICE OPTIONS

We support your project from the idea to the realization and gladly beyond.



We take into account quality and deadline requirements and we assume the responsibility for the project until turnkey handover.



Consulting

Use our experience for your tasks



Project Management

Support from the idea to the start of production



Risk Analysis

Identification of risks in the process



Custom design

Creation of individual solutions



Manufacturing

Successful manufacturing with modern technologies



Documentation

Clear and logical



Conformity

Compliance with standards and regulations



After Sales

Competent service through FFT



CONTACT

Your personal contact person

Markus Spitz
Head of Department Conveyor Technology

FFT Produktionssysteme GmbH & Co. KG
Schleyerstraße 1, DE-36041 Fulda
Phone: +49 (0) 661 2926 - 5401
Mobile: +49 (0) 511 - 7689814
E-Mail: markus.spitz@fft.de
www.fft.de

Christian Schuster
Sales Engineer

FFT Produktionssysteme GmbH & Co. KG
Schleyerstraße 1, DE-36041 Fulda
Phone: +49 (0) 661 2926 - 4276
Mobile: +49 (0) 160 - 94644642
E-Mail: christian.schuster@fft.de
www.fft.de



THANK YOU

Feel free to contact us.

WWW.FFT.DE | INFO@FFT.DE
TEL.: +49 (0) 661 2926-0

