

FFT *provi* **Turntable**

*„The **FFTprovi Turntable** is a decoupled system magazine which is able to request components in certain production cycles.“*

one step ahead in **INTELLIGENT** production systems



FFT*provi* Turntable

Decoupled system to provide components

1

Description

General operation of the **FFT*provi* Turntable**

2

Assemblies

Components of the **FFT*provi* Turntable**

3

Technical information

Connection details of the **FFT*provi* Turntable**

4

Advantages

Advantages and benefits for our customers

1

Description

General operations of the **FFT_{provi} Turntable**

one step ahead in **INTELLIGENT** production systems

General operation

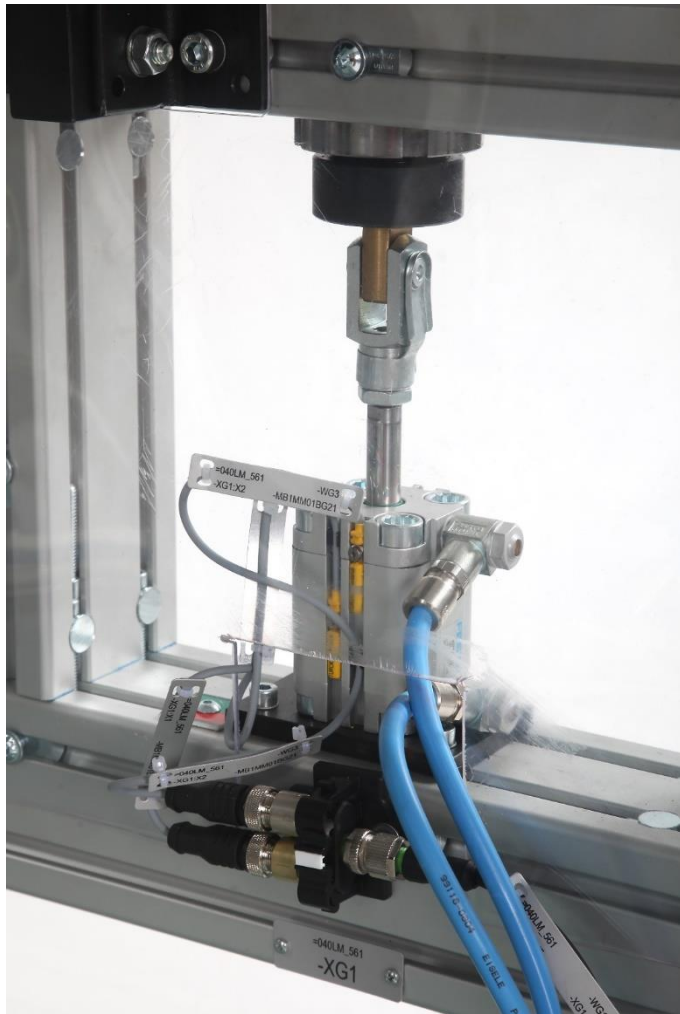

General operation

- The loading of the turntable can be done manually or automatically by using a robot.
- The discharge occurs after the rotation of the turntable by using a robot directly or by using a storage on pick and place units.
- The contact protection for the manual turntable is guaranteed by a traveling protection fence.
- Component queries are checking the filling level of the component storage continuously

2

Assemblies

Components of the **FFTprovi Turntable**

one step ahead in **INTELLIGENT** production systems

Assemblies

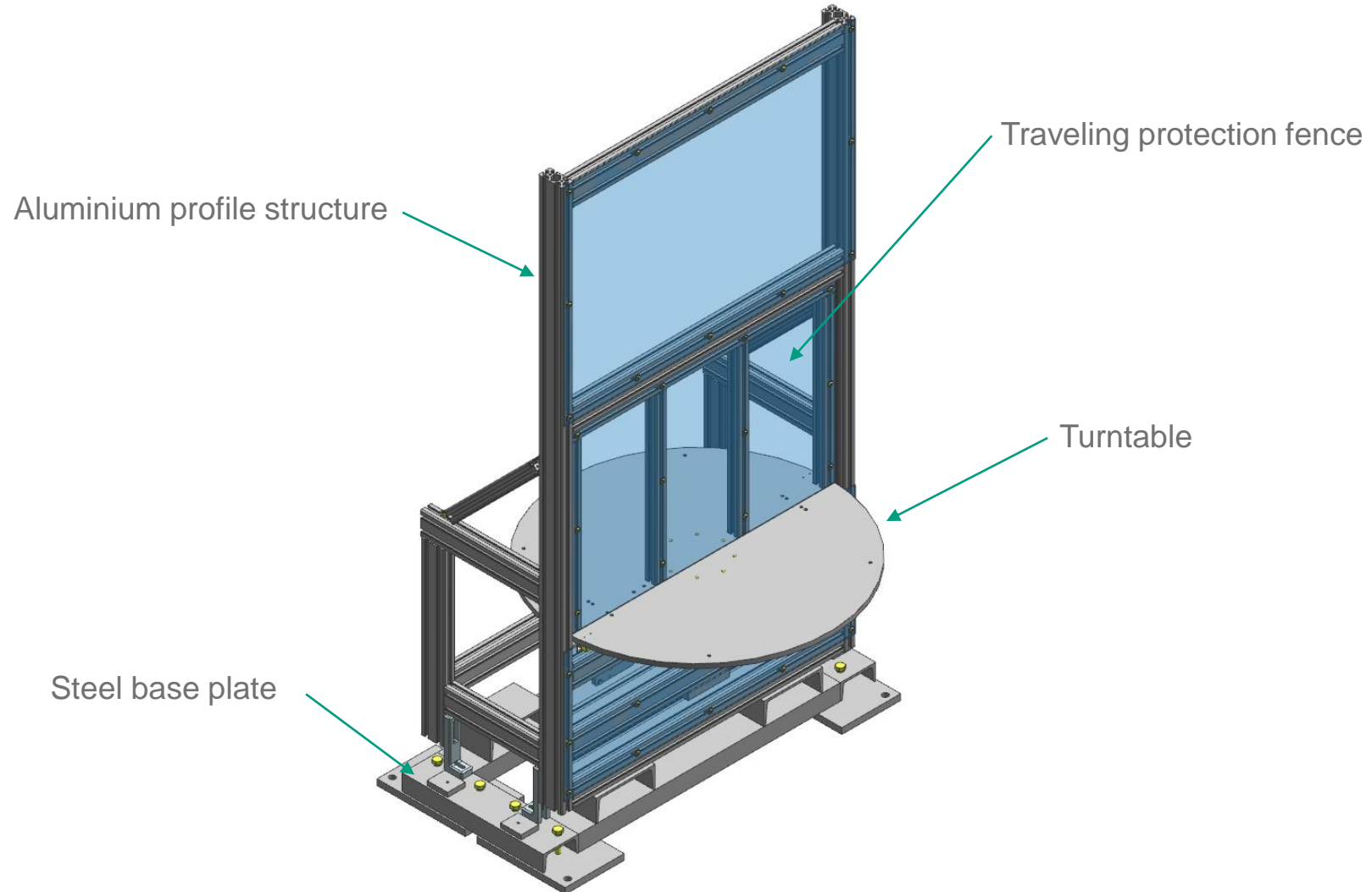

3

Technical information

Connection details of the **FFTprovi Turntables**

one step ahead in **INTELLIGENT** production systems



Technical data

Height	Individually adjustable
Diameter	Individually adjustable
Weight	According to the model
Air pressure	Min. 5 bar, max. 10 bar
Nominal voltage	230 V, 50 Hz
Positioning accuracy	± 0.5 mm
Additional load	Max. 200 kg

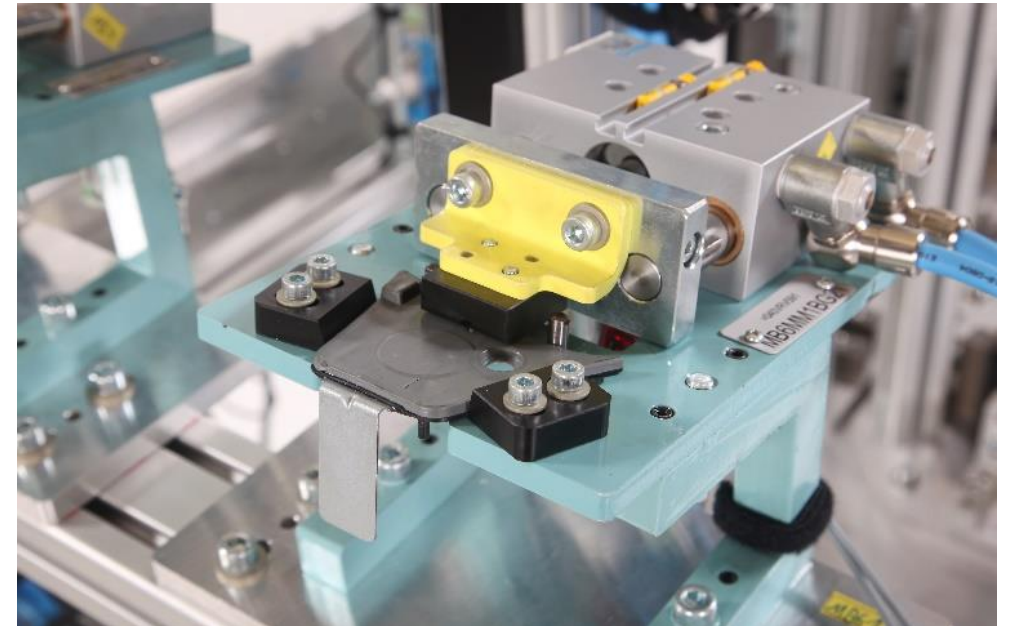



We support our customers in efficiently implementing their production systems according to their specifications.

“

DO YOU NEED AN
INDIVIDUAL SOLUTION
FOR YOUR TASK?

4

Advantages

Low-maintenance, individually calculable

one step ahead in **INTELLIGENT** production systems

Advantages

Advantages

- High degree of automation
- Big amount of storage possible
- Flexible adjustment to the part size
- Separation of the components possible
- Short cycle time
- Extremely robust



SERVICE OPTIONS

We support your project from the idea to the realization and gladly beyond.



We take into account quality and deadline requirements and we assume the responsibility for the project until turnkey handover.



Consulting

Use our experience for your tasks



Project Management

Support from the idea to the start of production



Risk Analysis

Identification of risks in the process



Custom design

Creation of individual solutions



Manufacturing

Successful manufacturing with modern technologies



Documentation

Clear and logical



Conformity

Compliance with standards and regulations



After Sales

Competent service through FFT



CONTACT

Your personal contact person

Markus Spitz
Head of Department Conveyor Technology

FFT Produktionssysteme GmbH & Co. KG
Schleyerstraße 1, DE-36041 Fulda
Phone: +49 (0) 661 2926 - 5401
Mobile: +49 (0) 511 - 7689814
E-Mail: markus.spitz@fft.de
www.fft.de

Christian Schuster
Sales Engineer

FFT Produktionssysteme GmbH & Co. KG
Schleyerstraße 1, DE-36041 Fulda
Phone: +49 (0) 661 2926 - 4276
Mobile: +49 (0) 160 - 94644642
E-Mail: christian.schuster@fft.de
www.fft.de



THANK YOU

Feel free to contact us.

WWW.FFT.DE | INFO@FFT.DE
TEL.: +49 (0) 661 2926-0

